



LEICA ABSOLUTE TRACKER AT401

Absolutely portable





LEICA ABSOLUTE TRACKER

Leica AT401. Absolutely portable

The [Leica Absolute Tracker AT401](#) is a portable coordinate measuring machine that allows extreme precision over ultra large distances. It is able to be powered by its own internal battery and is able to work in the most demanding environment, yet maintains the highest level of precision and the largest ever work envelope. The Leica Absolute Tracker AT401 has a unique "All in One" system design that incorporates such needed accessories as built in live video, level to gravity, environmental monitoring and even an integrated IR remote control. By utilizing the integrated Wireless LAN communication the sensor can be used completely wirelessly making this the most portable Absolute Tracker ever.



MEASURE WHERE NO OTHER CMM CAN GO



Especially large structures require highly accurate, flexible and portable metrology equipment. This surrounding is right for the Leica Absolute Tracker AT401. It redefines large scale portable measurement and opens the door for unprecedented metrology applications.

A new level of portability & durability

The complete measurement system weighs less than 15 kg including the case and in a minimum configuration it will fit into the overhead compartment of most commercial airliners. This is truly the world's most portable CMM.





MASTERING ANY INDUSTRY CONDITION



Ready for any environment

Utilizing a completely sealed design that is independently IP54 (IEC 60529) certified means this sensor can be installed in the most unforgiving environments. Spraying coolant, dust, weld splash, nothing is too harsh for this sensor. The Leica Absolute Tracker AT401 is the first laser tracker certified for outdoor use, even in the rain.



Absolute Tracker

Leica



Leica

POWERLOCK



Leica Geosystems introduced the world to PowerLock in 2009. This vision technology detects a reflector and automatically locks the laser beam onto it, even when the target is moving. The laser beam automatically moves to the reflector!

Laser Trackers without PowerLock require a high amount of skill and experience to learn how to efficiently use the sensor without breaking the beam. PowerLock changes this completely and makes the handling of a laser tracker much easier.









A WIRELESS ALL-IN-ONE LASER TRACKER



Cable-less operation

With two identical batteries – one in the sensor, one in the controller – the Leica Absolute Tracker AT401 can run for a work day. When power approaches a critical level, the batteries can be either replaced or hot swapped. The laser tracker continues running as if nothing had happened. With the built in WiFi connection the Leica Absolute Tracker AT401 becomes a completely wireless portable CMM free from any external data or power cable requirements.

Optionally the Leica Absolute Tracker AT401 is ready for Power over Ethernet. With this technology, a regular LAN cable supplies the sensor with both data and power.



Ultra Large Volume Measurements

With endless telescope rotation the sensor can measure a full 360° horizon and a 290° vertical dome. Pair this with a typical radial volume of 320 meters and you have the world's largest volume precision CMM.



Complete system integration

The Leica Absolute Tracker AT401 is ready for any measurement task that comes its way. All accessories such as remote control, environmental monitor or level sensor are already built in.



BOUNDARIES ARE THERE TO CROSS

Aerospace

The Leica Absolute Tracker AT401's portability and capability for one man operation make many challenging aerospace applications such as tool building and inspection, geometry check, part alignment, metrology assisted assembly or antenna construction much easier.

Off highway and heavy vehicles

Manufacturing vehicles of any type requires metrology equipment which helps to ensure top quality. Tool repeatability, vehicle inspection, line installation or line maintenance are just a few examples where the Leica Absolute Tracker AT401 excels. With an ultra large volume measurement and wireless operation these tasks can be completed easier than ever before.

Power Generation

Turbines and generators for use in wind or water power must withstand extreme conditions. For checking strict tolerances, ultra high accuracy is essential. The Leica Absolute Tracker AT401's portability and flexibility make large-volume shaft or machine alignment, machine inspection or blade measurement easy.

Research and science

When large structures and distances are the object of scientific activities, the Leica Absolute Tracker AT401 with a typical radial volume of 320 m is the right metrology tool. Ring survey or part inspections on an accelerator are just two examples.

Shipbuilding

Due to its infinite rotation and extreme measurement range, the Leica Absolute Tracker AT401 can handle even the ship building industry's gigantic dimensions when it comes to surveying, aligning engines and shafts or installing equipment.



EXPERTISE IN QUALITY

It all started with a theodolite. When Jakob Kern first constructed precision instruments in Switzerland of the 1830s, industry was in its early stages. But there is one lasting legacy – the commitment to absolute quality. Many Leica Geosystems instruments are still in daily use after several decades, as for example the first ever built Leica Geosystems laser trackers from 1990. Today, the Leica Geosystems metrology branch is a part of the global Hexagon Metrology network.

Where quality comes together

Every installed system is the result of individual consulting from a Hexagon Metrology sales engineer or a certified dealer. The definition of the metrology challenge is the initial step. Together with the future users, Hexagon Metrology develops the perfect package consisting of a Leica Geosystems sensor, suitable software and optional system extensions. After the purchase, Hexagon Metrology offers customized service and support for the entire instrument life.



LEICA ABSOLUTE TRACKER AT401 ACCURACY

All accuracies are specified with Leica Geosystems precision 1.5" Red Ring Reflectors (delivered with each sensor) and a measurement mode of 2 seconds per point under stable environmental conditions. Full range is specified as 1.5 to 80 meters away from the laser tracker within a vertical range of +/- 45°.

All accuracies are stated in maximum permissible error (MPE). Typical results are half of MPE.

U_{xyz} – Full Range

The measurement uncertainty of a coordinate "U_{xyz}" is defined as the deviation between a measured coordinate and the nominal coordinate of that point. This measurement uncertainty is specified as a function of the distance between the laser tracker and the measured point.

AT401: +/- 15 µm + 6 µm/m (+/- 0.0006" + 0.00007"/ft)

SPECIFICATIONS

Dimensions

Sensor Size: 290 x 221 x 188 mm (11.4" x 8.7" x 7.4")
Sensor Weight: 7.3 kg (16 lbs)
Controller Size: 250 x 112 x 63 mm (9.8" x 4.4" x 2.5")
Controller Weight: 0.8 kg (1.75 lbs)

Range

Infinite Horizontal Rotation: +/- 360°
Infinite Vertical Rotation: +/- 145°
Typical working Volume: 320 m

Environmental

Dust/Water: IP54 (IEC 60529)
Operating Temperature: 0°C to +40°C
Relative Humidity: Max. 95% (non-condensing)
Altitude: -700 to 5500 m (-2,300 to 18,000 ft)

Motorization

Acceleration: 360°/s²
Rotation Speed: 180°/s
PowerLock: 10° FOV

Absolute Angular Performance

Resolution: 0.07 arc Seconds
Accuracy (MPE): +/- 15 µm + 6 µm/m
(+/- 0.0006" + 0.00007"/ft)
Repeatability (MPE): +/- 7.5 µm + 3 µm/m
(+/- 0.0003" + 0.00004"/ft)
Inclination Setting Accuracy (2σ): +/- 1 arc second

Absolute Distance Performance

Resolution: 0.1 µm
Accuracy (MPE): +/- 10 µm (+/- 0.00039")
Repeatability (MPE): +/- 5 µm (+/- 0.0002")

Laser Emission

Class 2 Laser Product in accordance with the IEC 60825-1 Second Edition (2007-03)

General Information

Overview Camera (OVC)	4:3 IR enhanced Image ≈ 10° FOV
Environmental Monitor	Internal – Temperature, Pressure and Humidity External – Air Temperature – Object Temperature
Remote Control	Integrated 4 Button IR
Interfaces	Cable – TCP/IP (Cat5) Wireless – WLAN (IEEE 802.11g)
Power Management	Internal – lithium-ion battery External – AC power supply Optional – Power Over Ethernet (PoE+)

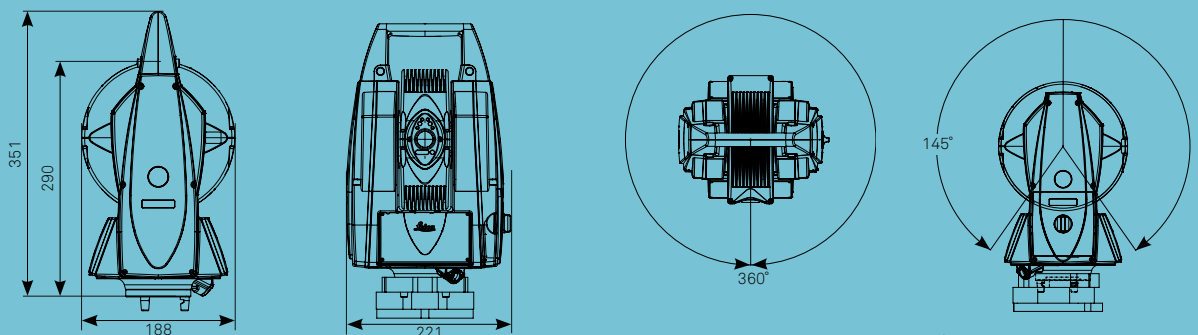

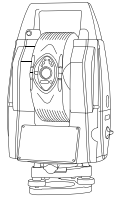

LASER TRACKERS & STATIONS



PORTABLE MEASURING ARMS

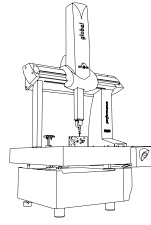

BRIDGE CMMs

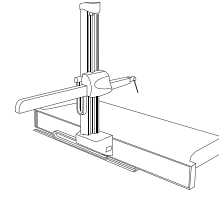

HORIZONTAL ARM CMMs

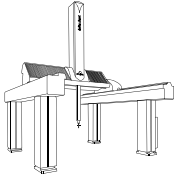

GANTRY CMMs

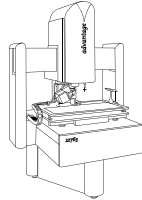

MULTISENSOR & OPTICAL SYSTEMS

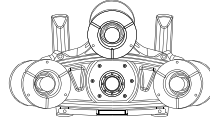

WHITE LIGHT SCANNERS

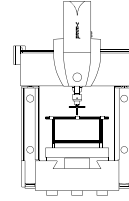

ULTRA HIGH ACCURACY CMMs

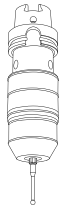

SENSORS

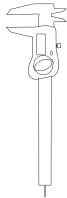

PRECISION MEASURING INSTRUMENTS



SOFTWARE SOLUTIONS



Hexagon Metrology offers a comprehensive range of products and services for all industrial metrology applications in sectors such as automotive, aerospace, energy and medical. We support our customers with actionable measurement information along the complete life cycle of a product – from development and design to production, assembly and final inspection.

With more than 20 production facilities and 70 Precision Centers for service and demonstrations, and a network of over 100 distribution partners on five continents, we empower our customers to fully control their manufacturing processes, enhancing the quality of products and increasing efficiency in manufacturing plants around the world.

For more information, visit www.hexagonmetrology.com

Hexagon Metrology is part of Hexagon (Nordic exchange: HEXA B). Hexagon is a leading global provider of design, measurement and visualisation technologies that enable customers to design, measure and position objects, and process and present data.

Learn more at www.hexagon.com

© 2012 Hexagon Metrology. Part of Hexagon

All rights reserved. Due to continuing product development, Hexagon Metrology reserves the right to change product specifications without prior notice. Printed in Germany, September 2012



Class 2 Laser Product in accordance with the IEC 60825-1, Second Edition (2007-03)